



Original Full Paper

# Fine Structure Analysis of White Spot Syndrome Virus of Shrimp

Yasuji Amano<sup>1</sup>, Linda Diaz C.<sup>1</sup>, Jose Melena C.<sup>2</sup>

<sup>1</sup>Instituto Nacional de Higiene y Medicina Tropical, Guayaquil, Ecuador

<sup>2</sup>CENAIM. Escuela Superior Politécnica del Litoral, Guayaquil, Ecuador

**Corresponding author:** Yasuji Amano, Instituto Nacional de Higiene y Medicina Tropical,  
Julián Coronel 905 y Esmeraldas Guayaquil, Ecuador.

E-mail: [jamano@rose.ocn.ne.jp](mailto:jamano@rose.ocn.ne.jp)

Submitted July 7<sup>th</sup> 2011, Accepted September 2<sup>nd</sup> 2011

---

## Abstract

White Spot Syndrome Virus (WSSV) was isolated from diseased shrimps presenting with clinical signs of WSSV infection. The seed virus was identified as WSSV by PCR, and used to inoculate to specific pathogen free (SPF) *P. vannamei* bloodstocks. WSSV was purified as described by Huang from infected gills from inoculated animals that were homogenized in a blender and partially purified by differential centrifugation. The final purification was carried out using density gradient in 10-40% NaBr and purified virus used for morphological analysis using transmission electron microscopy. A negative staining method using 2% PTA was used for purified virus, and electron staining with lead citrate and uranylacetate was used for ultra thin sections of infected tissues. This analysis determined that i) the spikes of intact virions could be clearly identified on the virion surface and on a partially broken envelopes, ii) the nucleocapsid structures were similar to those previously reported, even though the so called "ring" structure described previously was different and, iii) negative staining of purified WSSV fractions identified nucleosome like structures.

**Key Words:** WSSV, nucleocapsid, ring structure, nucleosome, virion spikes, aquatic organisms .

---

## Introduction

The White Spot Syndrome Virus appeared in Taiwan (1992), was first isolated from an outbreak in Japan and spread to several shrimp farming countries in the following few years (2).

The "stacked ring structure" of the WSSV nucleocapsid was first described by Wang et al. (3) and following additional analysis by Durand et al. (1), the nature of the WSSV ultra structure and morphology have been generally accepted. However, structural issues regarding the outer membrane (viral envelope) and nucleocapsid architecture and function remain unclear and therefore addressed in this report.

## Materials and Methods

### WSSV collection

Diseased shrimp with overt clinical signs of WSSV infection were collected from several local sources, and virus samples extracted from diseased animals were confirmed to contain WSSV by PCR. All samples were maintained at -80° C until used.

### WSSV infections

SPF *P. vannamei* bloodstocks were injected into the 2<sup>nd</sup> abdominal segment of uninfected shrimp with a diluted viral stock solution. Following disease onset, gills from inoculate shrimp were removed and double fixed with glutaraldehyde and osmic acid. Fixed tissues were then processed for ultra thin sectioning prior to analysis by transmission electron microscopy.

To prepare large WSSV quantities, gills were removed from infected shrimp, homogenized in a blender for 2min and, then centrifuged at 4,500 rpm for 5 min. Supernatants were centrifuged again at 8,000rpm for 20 min to clarify the viral suspension. The clear supernatant was then centrifuged at 25,000 rpm for 1 h to precipitate the WSSV which was then resuspended in

small volume of TEN buffer that was applied to a continuous gradient of NaBr (10-40%) and then centrifuged at 110,000 G, for 2 h. This resulted in a visible band in NaBr that was fractionated and kept at -80°C, until used.

#### *Transmission electron microscopy*

Ultra thin section and negative staining methods were used to analyze respective tissues. Double fixed tissues were embedded in SPI-Chem Spurr Formula Kit II resin and 50 nm sections generated using a Lica Ultracut with a diamond blade. Resulting sections were then treated with lead-citrate and uranylacetate solutions prior to electron microscopic analysis.

Some of the purified virus samples were then treated using a negative staining technique with 2% PTA and applied to carbon film covered 400 meshes. A transmission electron microscope (JEOL 1010) accelerating at 80 KV was used to carry out the analysis.

#### *Fourier transform of a nucleocapsid photograph*

To analyze fine structures associated with the nucleocapsid, a Fourier transform program from Image Sense (Higashitateishi 4-8-1-204, Katushika-ku, Tokyo, Japan) was used.

### **Results and Discussion**

The data presented in this report parallel some of the data presented by Durand et al., however, the interpretation of the data presented here has yielded different results.

Analysis of thin gill tissue sections by electron microscopy identified virus particles that had been cut different angles and with a crystallized protein mass (K) visible in the nucleus (Fig.1). It is not clear what the origin or functions of the crystallized protein, may be, however, it is similar in structure to what Durand et al defined as nucleocapsid precursor. The average virion diameter (at the maximum size available from the image) was estimated to be 105-110 nm with an outer membrane thickness of about 12 nm. The diameter of the nucleocapsid was estimated to be 70 nm and the nucleocapsid membrane thickness to be 5-6 nm. A wide gap was observed between the outer membrane and nucleocapsid.

Electron microscopic analysis of negatively-stained virion, demonstrated a spindle shape like structure with spikes on the outer membrane surface and an elongated outer membrane that has been referred to as a tail like structure (Fig. 2) similar to what was described by Durand (1). This "tail structure" has also described by Huang et al as being "similar to bacterial flagella" (3) and Sanches-Paz (4) and Escobedo-Banilla et al. (2) described as "swimming with the tail". However, this structure appears to be part of viral envelope and should therefore not be described as a typical WSSV Structure.

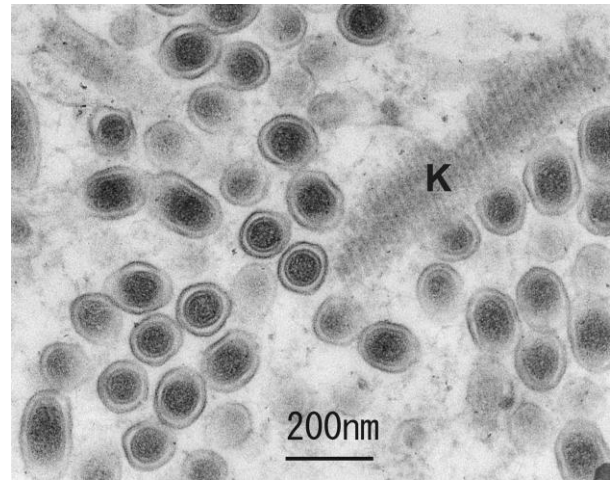

Figure 1. Electron microscopic analysis of gill tissue thin sections. A size difference between the outer membrane and nucleocapsid is apparent. The nucleocapsid is clear and the protein crystal is marked with a K. Magnification is indicated with a bar and figure in nanometer.

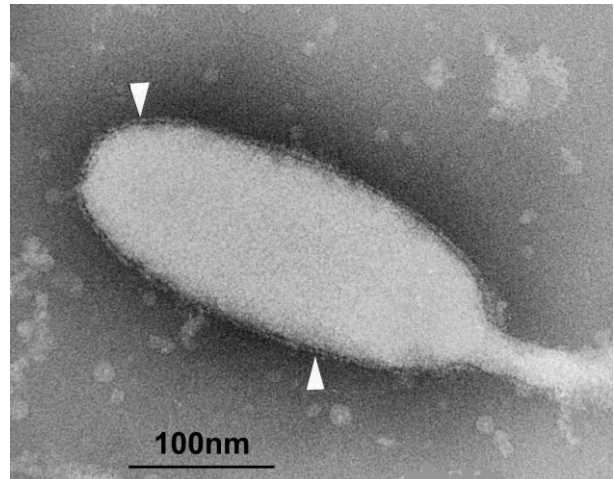

Figure 2. Electron microscopic analysis of a negatively-stained WSSV virion. Spikes are present as a "lace border".

Spikes present on the virus surface serve as a means of attaching to host cells (Proc. Nat. Acad Sci. 65(4) 115 b -1112, 1970) and it is clear that WSSV poses these structures. Analysis of a partially broken virion (Fig. 3) confirmed the outer membrane thickness of 10-12 nm which was more easily analyzed than intact virions. "Tadpole shaped" spikes measuring 5-6 nm in length with a diameter of the spike heads of 4-5 nm was observed (Fig.3, 4) and tadpole shaped spikes presented with a "lace border". Envelope spikes on the WSSV envelope have not been previously reported, however, Arturo Sanchez-Paz (4) described a spike model designating these structures as VP26 and VP28 and Xuahua Tang et al (5) described VP26 and VP28 as major WSSV envelope proteins. However, VP26 and VP28 were not exposed on the envelope surface and occupied 60% of the membrane protein content, suggesting that VP26 and VP28 could not be WSSV spike structures.

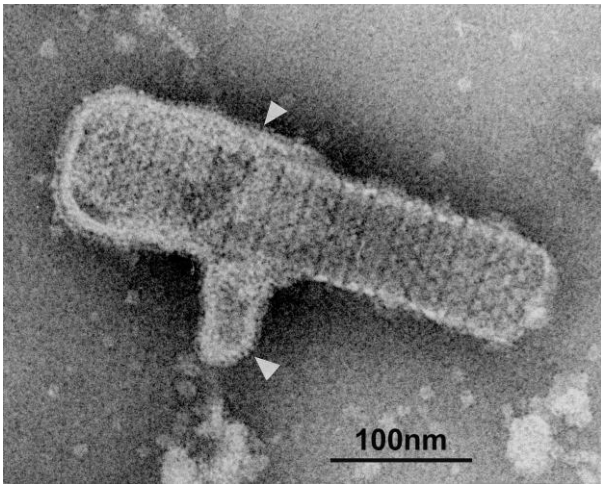

Figure 3. Electron microscopic analysis of a broken WSSV virion. Spikes can be seen clearly on the broken membrane.

The images described in Fig. 2 and 3 suggested that WSSV virions contained not only nucleocapsid but additional structure which conferred the spindle shape. Furthermore, thin section analysis of infected tissues (Fig. 1) suggesting that the diameter of outer membrane and of the nucleocapsid were significantly different and that the virion was formed by the nucleocapsid and an outer membrane (envelope). However, we can only speculate as to the existence of an additional structure capable of maintaining the virion's spindle shape.

Differences in the length of the naked nucleocapsid compared to the length of the intact virion were apparent. Analysis of the naked nucleocapsid demonstrated that it had an average width of 80 nm and an average length between 300-350 nm (Fig. 4A) or between 360-440 nm (Fig. 4B). These differences in nucleocapsid; length were associated with the nucleocapsid being either inside the virion or released from the virion as demonstrated by Huang et al (3), however, no explanations for the differences in length have been put forth to date. Comparison of the nucleocapsids described in Fig. 4 demonstrated variations in the distances between rings and it was clear that i) the rings were not united and that ii) between rings there existed a thin flexible structure conferring a loose connection between rings that could be observed following examination of a partially broken nucleocapsids (Fig. 5). This allowed for the visualization of the broken rings as a part of large fragments, suggesting the presence of a structure connecting the rings.

The ring diameter did not change at positions inside or out side the viral envelope and the ring diameter (diameter of nucleocapsid) was 70nm, however, negative staining analysis of naked nucleocapsid ring diameters showed them to be 80 nm in diameter. This is because empty nucleocapsids were crushed and a side view analysis provided a slightly larger diameter reading. Therefore, a 5 nm thick ring with a diameter of 70 nm collapsed to about 80 nm in diameter (Fig. 6).

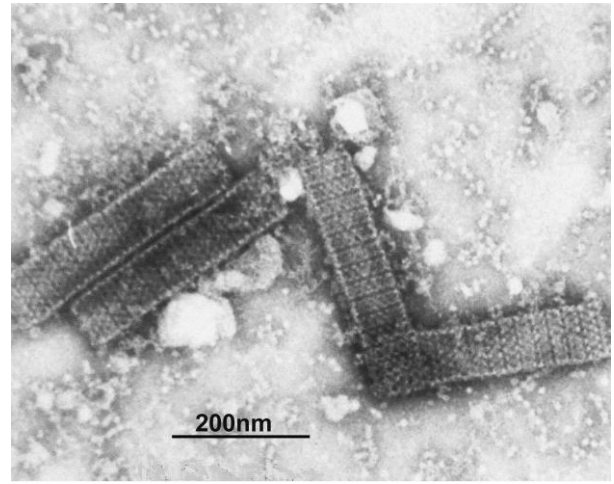

Figure 4. (A) Electron microscopic analysis of naked nucleocapsids. (A) Width average of 80 nm and a length of 300-350nm. Note the regularity of ring intervals.

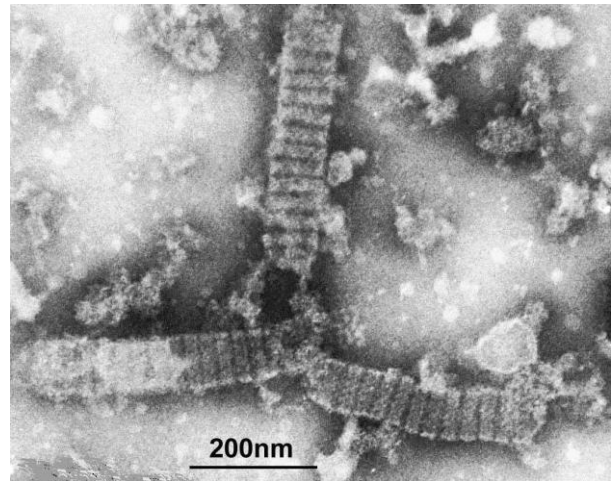

Figure 4. (B) Electron microscopic analysis of naked nucleocapsid. (B) An average width of 80 nm and an average length of 360-440 nm.

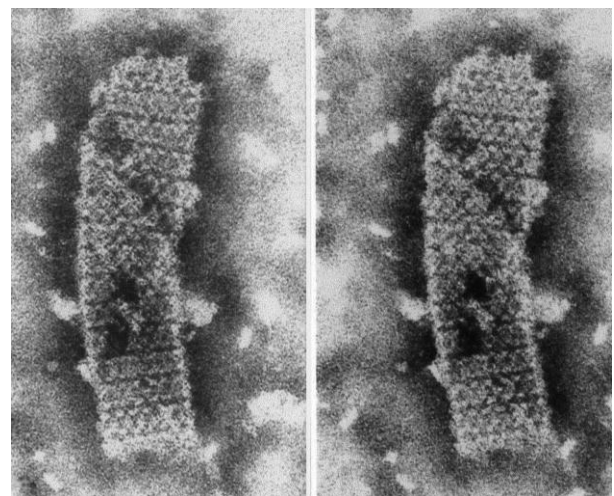

Figure 5. 3D photograph of partially broken nucleocapsid.

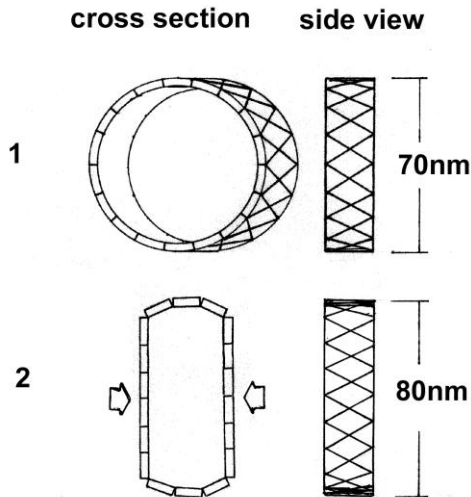

Figure 6. Electron microscopic analysis of WSSV nucleocapsid. Nucleocapsid analysis identified a diameter of 70 nm. An empty nucleocapsid had a 80 nm diameter.

Analysis of a nucleocapsid at a higher magnification revealed the structural units of the ring structure that presented as equilateral triangle and rhombus body units, that is the rhombus was comprised of two triangle body units united. This analysis demonstrated that one ring was composed of 36 triangle bodies and 18 rhombs bodies (or 76 triangle bodies). This is different from the general composition of virus capsid structures that typically present in icosahedral form and whose structural units (capsomers) are organized as “equilateral triangles”, that is, no known viral structures described previously are similar to those described for WSSV (Fig. 7).

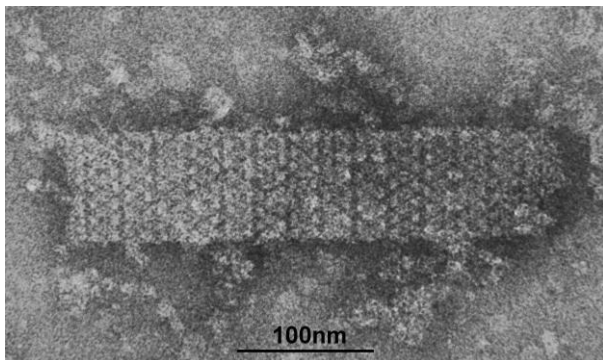

Figure 7. Electron microscopic analysis of WSSV nucleocapsid visualized using negative stain.

Previous investigators have described the WSSV ring structure as being formed from 14 spherical protein units, each sphere 8 nm in diameter with protein spheres not connecting to each other. However, this description is inaccurate since all structural units (capsomers) need to be jointed by edge to edge connection to provide structure integrity.

To resolve fine structure of the ring, we used the method described by Fourir et al. to transform EM

photographs and also further analyze the illustration generated by Huang et al. using the same methods (Fig. 8). This analysis demonstrated that the conclusions arrived at by Huang et al. were inaccurate.

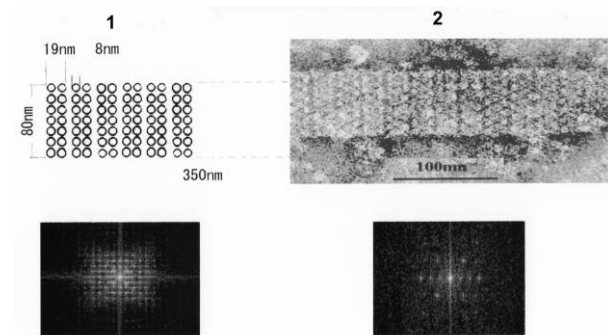

Figure 8. Fourier transformed patterns. (1) Huang et al model, (2) The same photograph as Fig. 7.

During our nucleocapsid studies we observed “pairs of beads”, forming filamentous substances (Fig. 9). The size of the beads were estimated to be 10-13 nm in diameter and similar to the “nucleosome”, basic chromatin unit. Durand et al. (1) described that “The content of the capsid seems to be a filamentous material released during degradation of nucleocapsid”, similar to the image describe in Fig. 9.

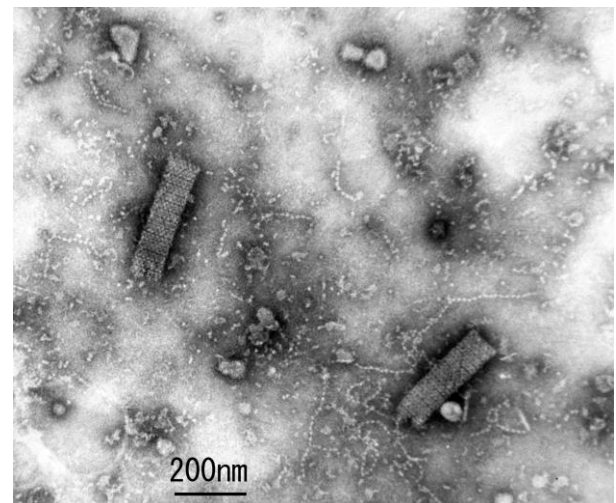

Figure 9. Electron microscopic analysis of "nucleosome" released from WSSV virions. Note the 10-13 nm diameter granules at regular distances.

Based on reports describing WSSV-DNA (chromatin), its size had been estimated between 293-307 kbp (4) and if, concentrated as a nucleosome, one WSSV virion posses 1,500 nucleosomes in a capsid (calculated as one nucleosome possessing 200bp of chromatin).

During the course of this study we observed that most of viral particles broke down into empty nucleocapsids, and nucleosome-like "pairs of beads" were found in the electron microscope images, suggesting that the WSSV virions were not very stable, that is, freezing loosened the outer envelope, nucleocapsids and released genetic material. This

phenomenon is characteristic to WSSV suggesting that in the context of this virus, the term "nucleocapsid" should not be used since these "nucleocapsids" did not serve their function, that is, maintain the genomic material intact. Therefore, the instability of the WSSV virion is likely related to the virion structure described as "empty gap" due to the large empty space present in the virion.

### Conclusion

Fine structure analysis of WSSV, better described the function and architecture of the WSSV nucleocapsid but did not reveal the mechanism resulting in the nucleosome unloading from the capsid. This may be difficult to address at present since this phenomenon has not been described in for other viruses.

The data presented suggested that WSSV did not possess a nucleocapsid similar to what has been described for other animal viruses and we suggest that it would be better to rename it a "pseudo nucleocapsid".

### References

1. DURAND S., LIGHTNER DV., REDMAN RM., BONAMI JR. Ultrastructure and morphogenesis of White Spot Syndrome Baculovirus (WSSV). *Dis. Aquat. Organ.* 1997, 29, 205-211.
2. ESCOBEDO-BONILLA CM., ALDAY-SANZ V., WILLE M., SORGELOOS P., PENSAERT MB., NAUWYNCK HJ. A review on morphology, molecular characterization, morphogenesis of white spot syndrome virus. *J. Fish Dis.* 2008, 31, 1-18.
3. HUANG C., ZHANG L., ZHANG J., XIAO L., WU Q., CHEN D., LI JK. Purification and characterization of White Spot Syndrome Virus (WSSV) produced in an alternate host; crayfish, *Cambarus clarkii*. *Virus Res.*, 2001, 76,115-125.
4. SANCHEZ-PAZ A.. White spot syndrome virus: an overview on an emergent concern. *Vet. Res.* 2010, 41: 43
5. TANG X., WU J., SIVARAMAN J., HEW CL. Crystal structure of major envelope proteins VP26 and VP 28 from White Spot Syndrome Virus Shed Light on Their Evolutionary Relationship. *J. Virology*, 2007, 81 (12), 6709-6717.
6. WANG CH., LO CF., CHUO JH., YEB PY., CHOU HY., TUNG MC., CHANG CF., SU MS., KOU GH. Purification and genomic analysis of baculovirus associated with white spot syndrome (WSBV) of *Penaeus monodon*. *Dis. Aquat. Organ.*, 1995, 23, 239-242.